

Department Visitors

Each year we invite internationally recognized scholars to the department to discuss new research developments. This past year we hosted a national conference and numerous international authorities.

In October, we hosted the Knowledge Based

2nd Kansas Conference

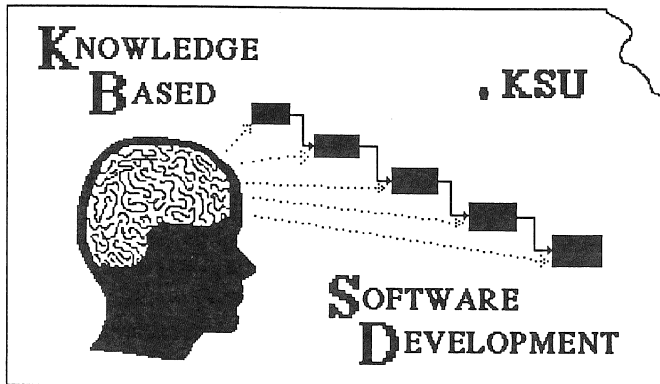

Software Development Conference. The goals of the conference were to advance the state-of-the-art of expert system technology in the area of software engineering and to provide a professional development experience for both students and faculty. It was very successful. More than twenty national experts in the area gave talks and led discussions assessing the current state of the technology and its future. These were leaders from both the academic and industry arenas. The conference was sponsored by local and national industries who view this area as vital to their long-term development.

Three researchers from Denmark visited the department during the past year as well.

Hanne Riis Nielson and Flemming Nielson came to KSU in August. Both hold posts as faculty members at Aalborg University, Aalborg, Denmark. Hanne Riis Nielson has researched in the areas of attribute grammars and programming logics. Her work appears in the journals "Mathematical Systems Theory," "Science of Computer

Programming," and a number of conferences. Currently, she is developing techniques for generating compilers from denotational semantics definitions. Flemming Nielson has published widely on the theory of data flow analysis, his articles appearing in the journals "Acta Informatica," "ACM Transactions on Programming Languages," "Proceedings of the ACM Symposium on Principles of Programming Languages," and a variety of conferences. He presently researches the mathematical theory of compiler generation. The two jointly hold a multi-year grant from the Danish government in support of their work. The Nielsons visited Kansas State University to present a status report on their efforts and consult with members of the department. Hanne Nielson spoke on "Code generation from two-level semantic definitions" and Flemming Nielson talked about "Flow analysis of two-level definitions."

Neil Jones, Professor of Datalogi ("Informatics") at the University of Copenhagen, presented a talk to the department in April. Jones is well known to many people in the department from his tenure as a professor at the University of Kansas from 1976 through 1979. He has written texts on computability theory and programming language principles and has edited a variety of texts and conference proceedings on topics such as compiler construction and data flow analysis. During the past three years, Jones and his research group at Copenhagen have developed a theory of "partial computation" that has particular relevance to target code improvement and compiler generation. The results have attracted world-wide interest, and Jones now holds a part-time post as a consultant to Hitachi of Japan. KSU's computing sciences department was one stop of a short tour of U.S. universities that Jones made. He spoke about the progress of the partial computation project and discussed compiling and type checking problems with several faculty.

AT&T Summer On-Campus Program

AT&T Information Systems has recognized the quality of KSU's Department of Computing and Information Sciences' graduate program in a very tangible way. Not only has the company made generous contributions in computer hardware, software and networking, it has sponsored selected AT&T employees to pursue an MS in this department each summer since 1980. AT&T's Corporate Education Center has sponsored up to seventy

AT&T employees at a time to enroll in KSU's summer on-campus graduate program. These student/employees can then transfer new technology to their jobs as well as make progress toward a graduate degree. Since its inception, sixty MS degrees have been awarded in this program. These students also bring "real world" applications to the classroom. This corporate partnership between KSU and AT&T has been beneficial to all involved.

Faculty Activities

Although it seems that faculty spend most of their time working with students, they perform a wide variety of activities that promote the department, the university, the state of Kansas, and the student population. In the past five years, the faculty has produced more than 75 research and tutorial articles and books. This has contributed to state-of-the-art computing in numerous areas. They have also participated in numerous professional activities. Dr. Unger was program chairperson for the 1987 national Sigsmall/PC conference. She has since been elected vice president of that organization. Dr. Gustafson and Dr. Wallentine were co-chairmen of the Knowledge Based Software Development Conference held at Kansas State University in October, 1986. Dr. Melton and Dr. Schmidt organized the Mathematical Foundations of Programming Languages conference at Tulane University. Dr. William Hankley chaired a panel at the 1987 SIGCSE conference on "Teaching Formal Specifications."

Congratulations are due to Dr. Austin Melton and Dr. David Schmidt for receiving NSF funding for their research work in Galois connections and their applications in computer science. It is important, foundational work which supports the future development of programming languages. Dr. Thomas Pittman has also received extramural funding from industry for his work in developing a transaction-oriented programming language.

Several other notes of interest include faculty on leave and new faculty. Dr. Myron Calhoun has spent the past year in Nigeria under a Fulbright teaching fellowship. In the past two years we have hired several new faculty who have strengthened both the applied and theoretical elements of the department. Dr. Pittman has been here two years. His areas of expertise are compilers and computer architecture. His hobby is small computers (especially the Macintosh), for which he is nationally known. Dr. Schmidt and Dr. Zamfir have been with us one year. Dr. Zamfir's areas of interest include artificial intelligence and theoretical models of concurrency. She has greatly strengthened and expanded our capabilities in both areas. Finally, this August Dr. Masaaki Mizuno joined us from Iowa State University. His research areas are operating systems and distributed systems. He is both talented and energetic and we welcome his arrival.

We have also lost several good faculty members. Dr. Rod Bates left us to try out private industry. He is building compilers for parallel machines. Dr. Roger Hartley has joined the faculty at New Mexico State University. He went there to join a colleague from Great Britain and work in their artificial intelligence lab. We are sad these people have left, but we wish them luck in their

new ventures. They will always be our friends.

The following is a list of the current faculty and their research and instructional interests.

Myron A. Calhoun, Associate Professor. B.S., University of Kansas, 1963; M.S., Colorado State University, 1964; Ph.D., Arizona State University, 1967; Researcher, Fairchild Research and Development Labs, Palo Alto, CA, 1967-1971; Asst. Prof., Elec. Engg., Kansas State University, 1971-1975; Research Fellow, U.S. Air Force Office of Scientific Research, 1984.

Major interests: Computer architecture, computer aided design, digital systems design, microcomputer applications.

Paul S. Fisher, Professor. B.S., University of Utah, 1963; M.A., University of Utah, 1964; Ph.D., Arizona State University, 1969.

Major interests: Database systems, network systems, distributed processing systems, perception pattern recognition.

David A. Gustafson, Associate Professor. B.S., University of Minnesota, 1967; B.S., University of Utah, 1969; M.S., University of Wisconsin, Madison, 1973; Ph.D., University of Wisconsin, Madison, 1979.

Major interests: Software engineering methodologies, software physics, validation techniques, AI techniques in software development, expert systems, software testing.

William J. Hankley, Professor. B.S., Northwestern University, 1962; M.S., Northwestern University, 1964; Ph.D., Ohio State University, 1967; Asst. Prof., University of Utah, 1967-1972; Computer Scientist, Programming Sciences Division, National Bureau of Standards, 1980-1981.

Major interests: Software engineering (environments, specification, verification), languages (Ada, Prolog, Modula2), graphic interaction.

Richard A. McBride, Assistant Professor. B.A., University of Colorado, 1968; M.S., Southern Illinois University, 1974; Ph.D., Kansas State University, 1980; Project Manager, NDX Corporation, Toronto, Ontario, 1980-1982.

Major interests: Computer networks, concurrent programming languages, operating systems, office information systems.

Austin C. Melton, Assistant Professor. B.A., Friends University, 1971; M.S., Kansas State University, 1974; Fulbright-Hays Fellow, Universitat Bremen, 1978-1979; Ph.D., Kansas State University, 1980; Asst. Prof., Marshall

Faculty Activities, continued

University, 1980-1982; Asst. Prof., Wichita State University, 1982-1984.

Major interests: Denotational semantics, software engineering, programming languages.

Masaaki Mizuno, Assistant Professor. B.S., Keio University, 1978; M.S., Keio University, 1980; M.S., Pennsylvania State University, 1982; Ph.D., Iowa State University, 1987.

Major interests: Operating systems, computer architecture, computer languages, computer security, distributed systems.

Thomas Pittman, Assistant Professor. B.S., University of California, Berkeley, 1966; Software Consultant, 1972-1985; M.S., University of California, Berkeley, 1980; Ph.D., University of California, Santa Cruz, 1985.

Major interests: Programming languages, compilers, VLSI computer design, expert systems.

David A. Schmidt, Assistant Professor. B.A., Fort Hays State University, 1976; M.S., Kansas State University, 1977; Ph.D. Kansas State University, 1981; Science and Engineering Research Council Research Fellow, University of Edinburgh, 1982-1983; Asst. Prof., Iowa State University, 1984-1986.

Major interests: Denotational semantics, applicating programming, natural deduction theorem proving.

Elizabeth A. Unger, Professor. B.S., Michigan State University, 1961; M.S., Michigan State University, 1963; Assoc. Dir., KSU Computing Center, 1970-1974; Ph.D., University of Kansas, 1978.

Major interests: Database systems, programming languages, computer science instruction, concurrency, office automation systems.

Maarten van Swaay, Associate Professor. Candidaat, University of Leiden, the Netherlands, 1953; Ph.D., Princeton University, 1956; Drs., University of Leiden, 1956; Senior Research Asst., University of Leiden, 1956-1959; Senior Staff, University of Eindhoven, the Netherlands, 1959-1963; Assoc. Prof., Chemistry, Kansas State University, 1969-1982.

Major interests: Computer architecture, microprocessors, instrumentation.

Virgil E. Wallentine, Professor and Head. B.S., Iowa State University, 1965; M.S., Iowa State University, 1970; Systems Analyst, Ames Lab., U.S. Atomic Energy Commission, 1967-1971; Ph.D., Iowa State University, 1972.

Major interests: Operating systems, computer networks, concurrent programming languages, knowledge engineering.

Maria Zamfir, Assistant Professor. Diplomate, University of Bucharest, Romania, 1960; Visiting Fulbright-Hays Scholar, University of California, Irvine, 1972-1973; Visiting Fulbright-Hays Scholar, University of California, Los Angeles, 1973-1974; Teaching Fellow, UCLA, 1982; Ph.D., UCLA, 1982; Computer Systems Specialist, Research & Development Dept., System Development Corp., Santa Monica, California, 1982-1984; Visiting Lecturer, UCLA, 1983-1986.

Major interests: Formal methods of concurrency, artificial intelligence, concurrent programming languages.

Keeping Track

We're interested in you! Please take a moment to fill out the information form below and return it to us.

Name _____

Street Address _____

City, State, Zip _____

Year graduated _____ Degree _____

My current company _____

My job or position _____

Questions for the newsletter _____

A Lab Science Coming of Age

Many of you fondly remember the hours you spent punching cards (and then dropping them) in the basement of Fairchild Hall. Replacing those lovable old machines in the Department of Computing and Information Sciences are state-of-the-art computing environments. We have achieved our goal of making interactive computing available to literally every class in the curriculum. At present, we have 20 Apple Macintosh computers, 60 AT&T Unix PCs, 60 PC-compatible systems, a VAX 11/780, 17 AT&T 3B minicomputers, several Artificial Intelligence workstations, and local area networking to completely interconnect them. In addition, there are 60 terminals connected to a data

switch which allows a user to sign on to any of the above machines plus the mainframe. All of the major operating systems are available: MS/DOS, Unix, and CMS. In addition, the department has a software inventory exceeding 150 unique packages.

Much of this lab equipment and software (\$1.7 million) was donated by private industry, principally AT&T. We feel that this generous support is in recognition of the quality of our program and the graduates it has produced. More equipment donations are expected. It is now our task to find the funds to maintain and improve the environment. At present, this computing environment rivals any found in middle western universities.

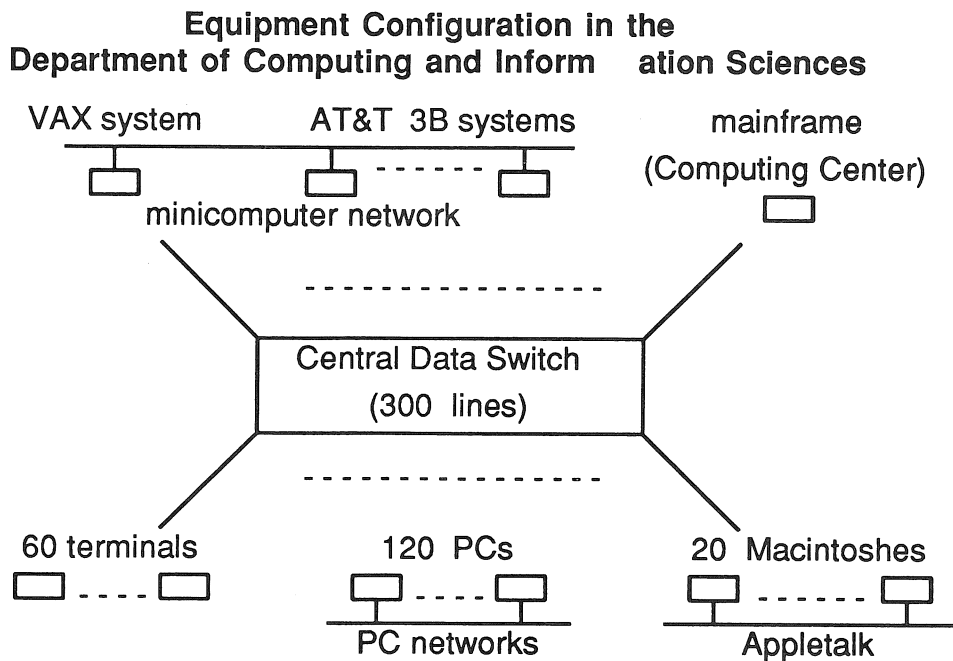

Machine room, Nichols Hall

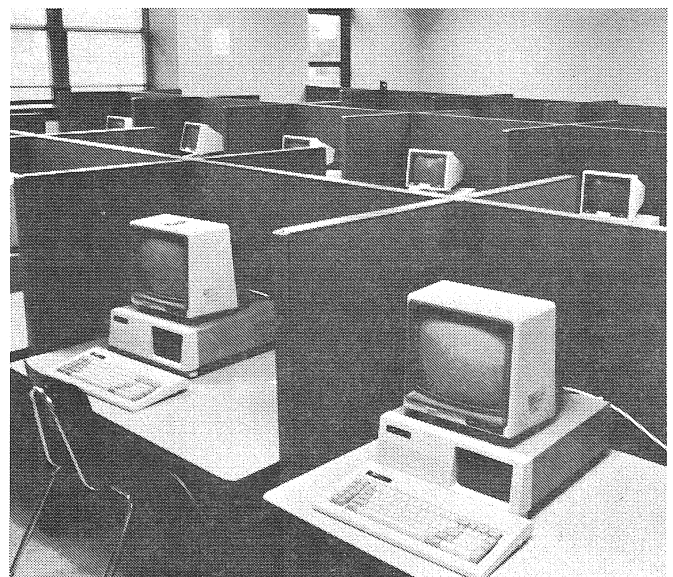

PC laboratory, Nichols Hall

The Computing and Information Sciences Development Fund

Private support of the Department of Computing and Information Sciences is the key to excellence for computing at KSU. At the present time all three major facets of the Kansas economy--agriculture, gas and oil, and the aircraft industry--are in trouble. The state of Kansas does what it can for the university by providing faculty salaries and physical facilities, but these aren't the only needs of a department. We have been successful in attracting equipment and software grants from industry (\$1.35 million in the last two years) to fill our computing laboratories. Industry, however, does not always provide the funding to maintain this equipment, or support and improve faculty and student development activities. Thus, private funding becomes extremely crucial to the success of the program, the faculty and the students.

We have three categories which we think are vitally important to the advancement of this department. First, we need to continue developing our department library so that students and faculty have access to current journals and technical reports, and so we can participate in the exchange of technical

reports with other major universities. Second, we must develop new sources of funds to support faculty and student development. This money will go towards invited seminar speakers for both students and faculty, small supplements for faculty research and class development materials, and support for faculty and student travel to professional meetings. The third major area in which we are currently lagging is scholarship and fellowship support. We need strength in this area in order to attract good students.

In order to meet these needs, we have established a special account in the KSU Foundation called the Computing and Information Sciences Development Fund (CIS Fund). If you would like to help us maintain a top quality program, please use the form below. Check with your employer, too. Many companies have a gift-matching program. We hope that your experience at KSU was positive, and that you'll want to support the department with your donation, large or small. We appreciate your help--thank-you!

Virgil E. Wallentine, Department Head

Yes, I want to help!

I want to support the Department of Computing and Information Sciences. Enclosed is my check for \$ _____ made payable to the KSU Foundation but designated to the CIS Development Fund.

I want to pledge my support for the Department of Computing and Information Sciences for:

\$1000 \$500 \$250 Other

to be paid in _____ installments. Enclosed is my first check for \$ _____. Please bill me annually for the next _____ years. I would prefer billing in the month of _____.

- Department library
- Faculty and student development
- Scholarships and fellowships

This gift does does not qualify for a matching gift from my employer.

Date _____ Class _____

Name _____

Street _____

City, State, Zip _____

Authorized signature _____

Business or employer _____

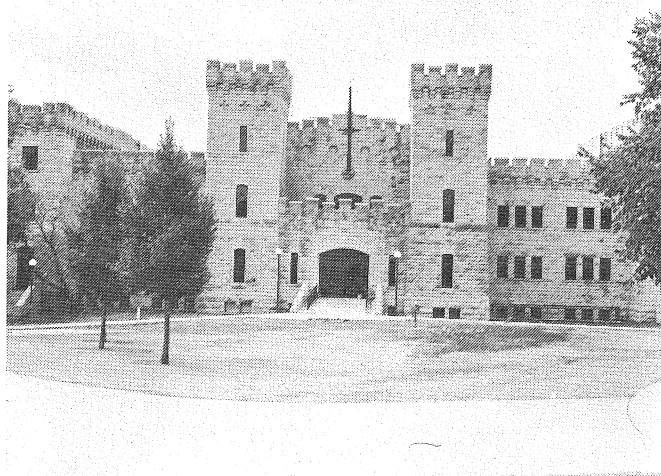

Please return to KSU Foundation, P.O. Box 1806, Manhattan, KS 66502.