

# Cadena: An Integrated Development, Analysis, and Verification Environment for Component-based Systems

John Hatcliff, William Deng, Matthew B. Dwyer, Georg Jung, Venkatesh Ranganath  
Kansas State University  
Department of Computing and Information Sciences  
Manhattan, KS 66506, USA  
{hatcliff,deng,dwyer,jung,rvprasad}@cis.ksu.edu

## ABSTRACT

The use of component models such as Enterprise Java Beans and the CORBA Component Model (CCM) in application development is expanding rapidly. Even in real-time safety/mission-critical domains, component-based development is beginning to take hold as a mechanism for incorporating non-functional aspects such as real-time, quality-of-service, and distribution. To form an effective basis for development of such systems, we believe that support for reasoning about correctness properties of component-based designs is essential.

In this paper, we present Cadena – an integrated environment for building and modeling CCM systems. Cadena provides facilities for defining component types using CCM IDL, specifying dependency information and transition system semantics for these types, assembling systems from CCM components, visualizing various dependence relationships between components, specifying and verifying correctness properties of models of CCM systems derived from CCM IDL, component assembly information, and Cadena specifications, and producing CORBA stubs and skeletons implemented in Java. We are applying Cadena to avionics applications built using Boeing’s Bold Stroke framework.

## 1. INTRODUCTION

As software systems become more distributed, developers are increasingly turning to component-based development frameworks such as Java Enterprise Beans (EJB) and the CORBA Component Model (CCM) to manage the complexities associated with building distributed systems. These frameworks aid application developers by providing services for common aspects such as distributed deployment, event notification, transactions, persistence, and security. Moreover, they use accepted design patterns (e.g., the event-oriented observer pattern) which enables a significant amount of code to be auto-generated. Component-based frameworks are also attractive because the relatively loose coupling between components facilitates reuse and allows systems to evolve gracefully as old components are switched out for new ones.

Even in the domain of distributed real-time embedded (DRE) systems where hard/soft deadlines and minimal foot-print requirements traditionally have led developers to eschew sophisticated middleware solutions, component-based infrastructures are growing more popular because hardware advances allow real-time and embedded

requirements to be more easily achieved. In addition, component-based infrastructures provide a framework for systematically introducing important domain aspects such time-triggered notification, real-time scheduling, and fault tolerance.

Boeing’s Bold Stroke program is an example where CORBA middleware has been embraced in a DRE domain for the reasons outlined above [19, 20, 8]. Bold Stroke is a product-line based program providing object-oriented mission critical avionics software to a variety of military aircraft produced by the Boeing company. Avionics software acts as the center of mission control for an aircraft pilot. It manages the cockpit displays, navigation and tactical sensors as well as weapon deployments. These complex systems have hard and soft real-time deadlines involving large amounts of periodic and aperiodic processing, and support thousands of operating modes. In addition, the software developed for military aircraft is maintained and updated over the course of many years. Although the development process is repeated for each update, each update aims to preserve as much legacy software as possible to reduce cost and risk. Bold Stroke represents a significant technological advance over Boeing’s previous mission computing development practices which were largely assembly code based.

There is a wide body of literature dealing with the theory of modeling distributed system and automated analysis of high-level state-based models using state-space exploration techniques such as model-checking. However, despite the popularity of component-based frameworks and their potential to be utilized in mission- and safety-critical applications, relatively little has been done to scale up these analysis techniques for the purpose of providing automated analysis tools for component frameworks. This is particularly the case with CCM – partly due to the fact that the CCM specification as part of CORBA 3.0 has only recently been finalized. Popular tools such as Rational Rose do not even provide design support for CCM yet.

To investigate the effectiveness of a variety of behavioral analysis techniques for component-based systems, we have built *Cadena*<sup>1</sup> – an integrated development environment for high-assurance CCM-based systems.

During the past year, we have been interacting extensively with Bold Stroke engineers who have proposed a variety of interesting challenge problems related to component-based design and analysis. Work on Cadena is driven in large part by a desire to provide solutions to challenge problems related to behavioral analysis. Bold Stroke was initiated before the OMG CCM specification process was underway. Thus, the Bold Stroke component design, is slightly different from CCM, and therefore does not apply the CCM Interface Definition Language (IDL) (now part of OMG CORBA IDL 3.0) to auto-generate component code. In current practice, component developers receive a natural language description of func-

Permission to make digital or hard copies of all or part of this work for personal or classroom use is granted without fee provided that copies are not made or distributed for profit or commercial advantage and that copies bear this notice and the full citation on the first page. To copy otherwise, to republish, to post on servers or to redistribute to lists, requires prior specific permission and/or a fee.  
Copyright 2001 ACM X-XXXXX-XX-X/XX/XX ...\$5.00.

<sup>1</sup>“Cadena” is a Spanish word meaning “network”. Cadena is also an acronym for Component Architecture Development Environment for Avionics systems.

tional and real-time requirements along with UML collaboration diagrams built with Rose showing component interactions, and development begins directly with C++ coding. This means that high-level designs are not tool-leveraged in any way (either for code generation or for automated analysis). Bold Stroke engineers have suggested a number of interesting ways that high-level designs could be analyzed for event/data dependency and mode state information for the purpose of inferring distribution, scheduling, and real-time aspects, as well as checking for common design flaws and satisfaction of application specific requirements.

Beyond the particular domain of DRE mission/safety-critical systems, we believe that CCM and other component oriented frameworks are excellent vehicles for injecting light-weight formal methods and sophisticated automated analysis techniques across the entire software development process. In the past, it has often been difficult to get developers to write formal specifications – instead they prefer to move quickly to writing code. We believe that this is because there is little tool support for leveraging such high-level descriptions. In contrast, CCM’s IDL (which defines the structure of components) and CCM’s component assembly descriptions (which describe how components are connected together) are central to the use of CCM since a large percentage of a system’s code is generated directly from these. These high-level descriptions can be leveraged in a number of ways: component connections can be visualized (essentially, UML collaboration diagrams can be autogenerated), useful dependency analysis can be performed at this level, light-weight behavior specifications can be incorporated, and code generation can be tailored to produce code that is more amenable to verification and certification. When applying model-checking techniques, one often struggles to find appropriate system abstraction that make state exploration tractable. CCM descriptions naturally form system abstractions, and by varying annotations on the high-level descriptions (e.g., to expose the state of mode variables, etc.) the system model processed by model-checking techniques can be easily abstracted (to hide state) or refined (to expose more state and more interesting behaviors).

Cadena provides the following capabilities for development of CCM systems.

- A collection of light-weight specification forms that can be attached to IDL to specify mode variable domains, intra-component dependencies, and component state-transition semantics. These forms have a natural refinement order so that useful feedback can be obtained with little annotation effort, and increasing the precision of annotation yields more precise analysis. In addition, Cadena specifications allow developers to specify the same information in different ways, achieving a form of *checkable redundancy* that is useful for exposing design flaws.
- Dependency analysis capabilities allow tracing inter/intra-component event and data dependencies, as well as algorithms for synthesizing dependency-based real-time and distribution aspect information.
- A novel model-checking infrastructure dedicated to event-based inter-component communication via real-time middleware enables system design models (derived from CCM IDL, component-assembly descriptions and annotations) to be model-checked for global system properties.
- Java component stub and skeleton code generated using the OpenCCM [11] CCM IDL to Java compiler.
- A component assembly framework supporting a variety of visualization and programming tools for developing component connections.
- A CCM deployment facility dedicated to the Boeing Bold Stroke architecture (static component connections with a real-time event-channel) that allows deployment code to be automatically generated.

- The Cadena tools are implemented as plug-ins to IBM’s Eclipse IDE. This provides an end-to-end integrated development environment for CCM-based Java systems.

Several of these facilities are targeted directly to the avionics domain, but clearly the Cadena is useful in many respects for CCM development in general. Although Cadena currently emphasizes Java in its back-end facilities, since CCM is language-neutral, Cadena’s front-end design capabilities are not Java dependent. Moreover, back-end capabilities can be easily extended in the future to other languages, for example, C++ using OpenCCM’s [11] planned support for C++. Other development systems such as MetaH [23] support several important aspects for DRE systems that Cadena does not, such as timing and schedulability analysis, reliability and fault analysis, as well as sophisticated deployment strategies. The primary motivation for our work is to build a system that is robust enough for development of real systems with the goal of assessing the effectiveness of applying static analysis, model-checking, and other light-weight formal methods to CCM-based systems.

The rest of this paper is organized as follows. Section 2 gives a brief overview of CCM and the Bold Stroke architecture, and presents an example that will drive the discussion in the rest of the paper. Section 3 outlines the Cadena architecture and illustrates the various Cadena specification forms. Section 4 presents Cadena’s dependency analysis facilities. Section 5 describes Cadena’s model-checking facilities. Section 6 discusses related work. Section 7 assesses the current state of the tools and presents directions for future work.

## 2. CCM OVERVIEW AND EXAMPLE

To describe the features of Cadena, we will use as a running example a simple avionics system that shows steering cues on a pilot’s navigational display. The pilot can choose between two different display modes — each mode yields a different set of steering cues. A *tactical* display mode displays cues related to a tactical (*i.e.*, mission) objective. A *navigation* display mode displays cues related to a navigational objective. Cues for the navigation display are derived in part from navigation steering points data that can be entered by the navigator.

Figure 1 presents the CCM architecture for the example system. The system is realized as a collection of components coupled together via interface and event connections. Input position data is gathered periodically at a rate of 20 Hz in the GPS component and then passed to an intermediate `AirFrame` component (which in a more realistic system would take position data from a variety of other sensors). Both the `NavSteering` and `TacticalSteering` component produce cue data for `Display` based on air frame position data. The `Navigator` component polls for inputs from the plane navigator at a rate of 5 Hz that are used to form `NavSteeringPoints` data. This data is then used to form navigational steering cues in `NavSteering`. `PilotControl` polls for a pilot steering mode at a rate of 1 Hz and enables or disables `NavSteering` and `TacticalSteering` accordingly.

Figure 2 gives the CCM IDL that defines the component types `BMLazyActive` and `BMModall` for the `AirFrame` and `TacticalSteering` component instances in Figure 1. CCM components *provide* interfaces to clients on ports referred to as *facets*, and *use* interfaces provided by other clients on ports referred to as *receptacles*. Components *publish* events on ports referred to as *event sources*, and *consume* events on ports referred to as *event sinks*. In the `BMLazyActive` component type of Figure 2, `dataOut` is the name of a facet with interface type `DataAvailable`, and `dataIn` is the name of a receptacle with interface type `DataAvailable`. Similarly, `inDataAvailable` is the name of an event sink of type `DataAvailable`, and `outDataAvailable` is the name of an event source of type `DataAvailable`. Components can also have *attributes* such as `modeVar` that are used either in component

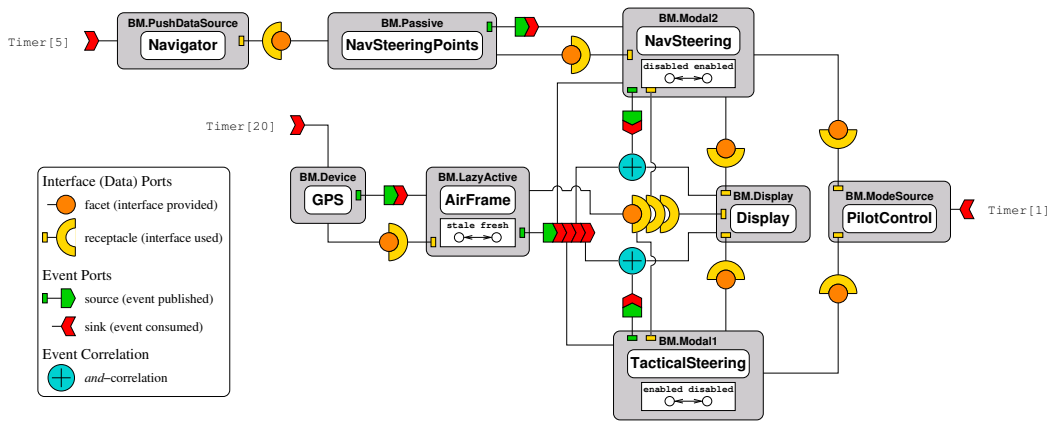

Figure 1: Simple avionics system

```
#pragma prefix "cadena"
module modalsp {
  interface ReadData {
    readonly attribute any data;
  };

  eventtype Timeout {};
  eventtype DataAvailable {};

  enum LazyActiveMode {stale, fresh};
  component BMLazyActive {
    provides ReadData dataOut;
    uses ReadData dataIn;
    publishes DataAvailable outDataAvailable;
    consumes DataAvailable inDataAvailable;
    attribute LazyActiveMode dataStatus;
  };

  enum OnOffMode {enabled, disabled};
  interface ChangeMode {
    attribute OnOffMode modeVar;
  };

  component BModal1 {
    provides ChangeMode modeChange;
    provides ReadData dataOut;
    uses ReadData dataIn;
    publishes DataAvailable outDataAvailable;
    consumes DataAvailable inDataAvailable;
  };
};
```

Figure 2: CCM/Cadena artifacts for ModalSP (excerpts)

configuration or to represent some other aspect of component state. For an attribute with name *attrname*, the IDL compiler will automatically generate an accessor method *get\_attrname* and a mutator method *set\_attrname*. If the attribute is declared *readonly* as in the *ReadData* interface of Figure 2, then only an accessor method is generated<sup>2</sup>.

While CCM allows components to be dynamically created and (dis)connected, Bold Stroke applications follow typical practice in safety/mission-critical systems and employ a static component allocation and configuration policy by creating and connecting components only in a system initialization phase. The CORBA 3.0 specification does not provide a dedicated language for static system configuration. Cadena provides graphical, textual, or form-based incremental static configuration facilities with the abstract syntax tree of the textual form providing the canonical representation. Figure 3 displays a fragment of the textual Cadena Assembly Description (CAD) for the example system. In CAD, a developer declares the component instances that form a system, along with event channel rate groups and abstract distribution locations. For each instance, a developer specifies an abstract location upon which

<sup>2</sup>The name of the accessor/mutator methods are dependent on the IDL to language mapping.

```
system ModalSPScenario {
  import cadena.common, cadena.modalsp;

  Rates 1, 5, 20; // Hz rate groups
  Locations 11, 12, 13; // abstract deployment locs
  ...
  Instance AirFrame implements BMLazyActive on #LALoc {
    connect this.inDataAvailable
      to GPS.outDataAvailable runRate #LARate;
    connect this.dataIn to GPS.dataOut;
  }
  Instance TacticalSteering implements BModal1 on 12 {
    connect this.inDataAvailable
      to AirFrame.outDataAvailable runRate 5;
    connect this.dataIn to AirFrame.dataOut;
  }
  ...
};
```

Figure 3: Cadena Assembly Description for ModalSP (excerpts)

the instance is to be allocated. Abstract locations are mapped to CORBA specific notions such as containers and nodes at deployment time. For receptacle and event sink ports, a *connect* clause declares a connection between a port of the current instance and a port of the component that provides the interface/event. This follows a convention that connections are declared on the client-side of an interface/event connection. Each event sink port connection uses the *runRate* clause to indicate which rate group thread should run the event handler upon event dispatch. Incomplete specifications and incremental construction are supported by allowing rate and location variables such as *#LALoc* and *#LARate*. These act as place holders, and values for these can be inferred using the non-functional aspect synthesis algorithms presented later. Equality constraints between such variables can also be specified, and the synthesis procedures generate output that conforms to these constraints. A type-checking procedure ensures well-typed connections.

Bold Stroke applications follow a *control-push data-pull* architecture in which data is transferred between data producer and data consumer components in a two step process. First, a data producer (e.g., *TacticalSteering*) publishes a *DataAvailable* event indicating that it has updated some data that is ready to be consumed. Then, when a subscribing data consumer (e.g., *Display*) receives the event, it calls a *get data* accessor method in a facet provided by the supplier to retrieve the data. Thus, threads never block waiting for data to become available, and this simplifies the design of real-time aspects. Under this strategy, component connections come in pairs consisting of an event connection for notification that data is ready, and an interface connection for fetching the data.

The *BMLazyActive* component type of Figure 2 implements a variant of this strategy to handle situations where a component *C* (e.g., *AirFrame*) depends on data that is updated much more

frequently than  $C$ 's clients require  $C$ 's data. For example, the `AirFrame` component does not fetch data immediately from GPS when notified, but instead simply sets its `dataStatus` attribute to indicate that its data is stale and notifies its clients (e.g., `TacticalSteering`) that its data is available. When a `get data` call for `AirFrame` data comes from one of its clients, it checks the `dataStatus` attribute to see if its data is fresh, and if it is, it returns it immediately to the calling client. If it is not fresh, it calls the `GPS get data` method, updates its own data with the return GPS data, sets its `dataStatus` to fresh, and returns the new `AirFrame` data to the calling client.

Both `NavSteering` and `TacticalSteering` are *modal components* that have two modes (enabled, disabled). These modes are set by `PilotControl` via `ChangeMode` facets provided by the modal components. When a modal component is disabled, any events received are simply discarded by the component. When enabled, the component responds according to the control-push data-pull strategy (e.g., `TacticalSteering` responds to a `DataAvailable` from `AirFrame` by calling `AirFrame`'s get data method).

In Bold Stroke applications, even though at a conceptual level component event source ports are connected to event sink ports, in the implementation, event communication is factored through a real-time CORBA event channel. Use of such infrastructure is central to Bold Stroke computation because it provides not only a mechanism for communicating events, but also a pool-based threading model, time-triggered periodic events, and event correlation. In order to shield application components from the physical aspects of the system, for product-line flexibility, and for run-time efficiency, all components are *passive* – component methods are run by event-channel threads that dispatch events by calling the event handlers (“push methods” in CORBA terminology) associated with event sink ports. The roots of computation are time-triggered events (e.g., events associated with event sinks of `Navigator`, `GPS`, and `PilotControl`) supplied at a specified rates by the event-channel. Dispatching of these events causes the dispatch threads to run the associated handlers which contain methods calls and publishing of subsequent events. In the current Bold Stroke implementation, the event channel thread pool has exactly one thread associated with each rate. As noted earlier in the discussion of Figure 3, each non-time-triggered event port also has a rate specified at configuration time which indicates its *rate group*, i.e., the pool thread that should run the event handler when the event is dispatched.

The event channel also provides event correlation and event filtering mechanisms. In the example system, *and*-correlation is used, for instance, to combine event flows from `NavSteering` and `AirFrame` into `NavDisplay`. The semantics of *and*-correlation on two events  $e_1$  and  $e_2$  is that the event channel waits for an instance of both  $e_1$  and  $e_2$  to be published before creating a notification event that is dispatched to the consumer of the correlation. The semantics of a correlator is defined by an automaton over event traces derived from the correlation expression [21].

Note that CCM IDL captures the interface properties of components – Cadena's notation for capturing interesting high-level behavioral patterns is presented in the next section.

### 3. CADENA ARCHITECTURE

Figure 4 displays the internal structure of the Cadena toolset. Cadena projects contain four high-level specification forms: a CORBA 3 IDL file that defines the structure of component types (see Figure 2), a Cadena Property Specification (CPS) file that specifies various aspects of component behavior (see Figure 5), a Cadena Assembly Description (CAD) that specifies the components instances that form the system, the connections between them, along with other real-time and distribution property information, and a specification file that stores information about the desired correctness properties of the system. These input artifacts are created using

```

component BMLazyActive {
  mode dataStatus;
  dependencydefault == none;

  dependencies {
    case dataStatus of {
      stale: inDataAvailable -> outDataAvailable;
              dataOut.get_data(); -> dataIn.get_data();
      fresh: inDataAvailable -> outDataAvailable;
    }
  }

  behavior {
    any internalData;

    dataAvailable.push(_) {
      if (dataStatus == fresh)
        dataStatus = stale;
      outDataAvailable.push(_);
    }

    any dataOut.getData() {
      if (dataStatus == stale) {
        internalData <- dataIn.get_data();
        dataStatus = fresh;
      }
      return internalData;
    }
  }
}

component BMDevice {
  behavior { ... }
}

component BModall {
  mode modeChange.modeVar;
  dependencydefault == all;

  dependencies {
    modeChange ->;
    case modeChange.modeVar of {
      enabled: inDataAvailable
                -> dataIn.get_data(),
                outDataAvailable;
      disabled: inDataAvailable ->;
    }
  }

  behavior { ... }
}

```

Figure 5: Cadena Property Specification (CPS) (excerpts)

customized editors built using Eclipse plug-in facilities. In particular, the CAD format has a textual editor, a graphical editor (to view systems as graphs similar to style of Figure 1)<sup>3</sup>, and a form-based editor that allows one to easily define different projections of the component assembly (e.g., connections only, distribution and rate assignments only, etc.). The graph structure described by the CAD is the basic data structure that is used by the dependency analyzer (discussed in Section 4), the graphical view displayer, and the deployment code generator (which generates Java code to allocate and connect components).

Figure 5 displays excerpts of the CPS file for our example system. In a CPS description, developers may declare intracomponent dependencies between ports and simple behavioral descriptions of a component's event handlers and other methods. The dependence declarations take the form *trigger-port-action* -> *response-port-action*. For example, Figure 5 declares that consumption of an event on the `inDataAvailable` port of a `BMLazyActive` component may trigger a publish on the `outDataAvailable` port in both *state* and *fresh* modes. The absence of a dependence for the `dataOut` port in the *fresh* mode indicates that any call on

<sup>3</sup>We do not use an actual screen shot for Figure 1 because the current version of Eclipse does not include zoom in/out capabilities, and the current layout is too large to fit on a screen.

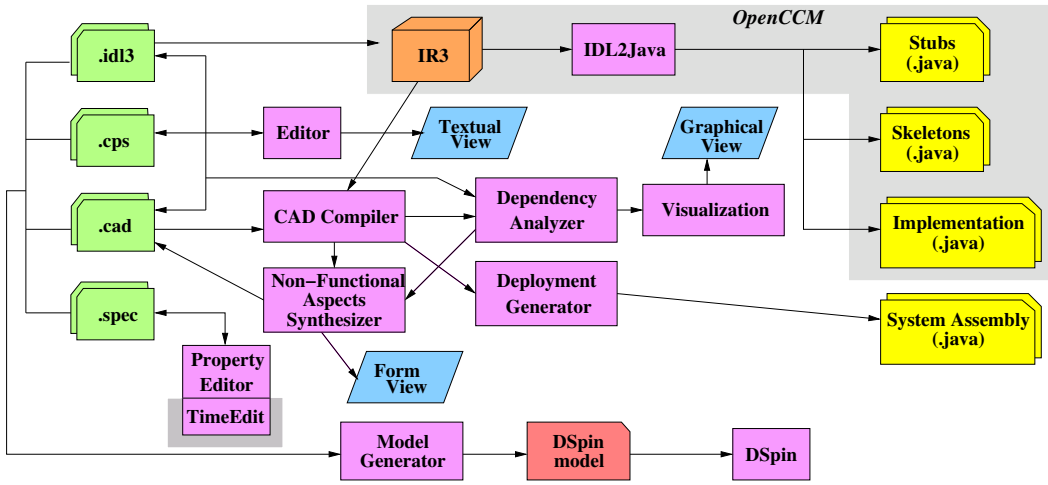

Figure 4: Cadena architecture

`dataOut` should not result in an action on any other port.

A `dependencydefault` may have one of two settings: a `none` setting allows developers to start with an empty dependence relation and add new dependencies (i.e., dependences do not exist except when declared), an `all` setting allows developers to start with a universal dependence relation and then prune dependences (i.e., by default all possible dependencies between ports exist). In the `all` setting, once a port is mentioned on the left-hand-side, then only declared dependencies apply for that port. For example, for `BMModel1` which has the `all` setting, the absence of declarations for the `dataOut` port specifies that the ports (`outDataAvailable` and `dataIn`) *do depend* on `dataOut` (note that is an overapproximation of the actual behavior). Dependencies are pruned in `BMModel1` by giving refining declarations such as those for the `modeChange` and `inDataAvailable` ports that list no dependents to the right of the `->`.

Since transition systems for model-checking are generated from behavioral descriptions, their primary purpose is to capture (a) the actions that one wishes to reason about in temporal specifications and (b) simple control-flow relationships between these actions. Cadena supports such observable actions as event publish and consume, method call and return, data flows between system variables, assignments to mode variables. Each behavioral description in the CPS format gives both a data and control abstraction of a component’s actual implementation of an event handler or method. Data abstraction is achieved by only exposing concrete values of mode variables (or other application variables with bounded domains). This was motivated by the fact that Bold Stroke engineers are primarily concerned with reasoning about modal behavior at design time since analysis of system modes and mode transitions can be leveraged in several ways. Even though concrete values of other application variables are usually not modeled, data flows between such variables can be captured. For example, `internalData <- dataIn.getData();` in the `LazyActive` behavior models a flow from the result of the `getData();` method into the `internalData` variable. This may abstract many actual computation steps in the actual implementation. The behavioral language contains simple control structures such as sequencing and conditionals and abstracts control by simple omitting commands from the implementation that one does not wish to observe. Note that dependence information can also be derived from behavioral specification, and this provides a form of checkable redundancy. The intent is that developers begin with the more light-weight dependence specifications, leverage those, then only move to the more verbose behavioral specifications when model-checking analysis is to be applied.

Cadena uses the OpenCCM tools [11] to generate system im-

plementations. The OMG CORBA 3.0 specification standardizes a strategy for compiling IDL (of which the CCM IDL is part) down to CORBA IDL 2, which can then be translated to an underlying implementation language such as Java or C++. This translation process automatically generates a substantial amount of infrastructure code for tasks such as component creation and connecting and disconnecting ports. The output code contains the usual CORBA *stubs* and *skeletons*, along with skeleton *implementations* of component methods and event handlers. With this code generation, the developer only needs to implement event handlers and methods on provided interfaces.

When applying model-checking, a partial transition system is generated from the system IDL3, CPS, and CAD inputs. This is then composed with a transition model of the CORBA event channel to obtain a complete model of system behavior. Transition system and selected system properties are then submitted to the DSpin model-checker for analysis. Counter-examples are rendered in terms of actions defined in the Cadena models, e.g., event publishes and method calls.

When building systems with Cadena, we intend for developers to take the following steps: (1) load a library of domain-specific components and associated CPS specifications, (2) define new project-specific components and associated behavioral CPS specifications, (3) use various supported editors to configure connections between components, (4) use dependency viewer to examine dependencies, (5) use non-functional aspect synthesis tools to attach distribution and rate information, (6) specify desired global correctness properties, (7) generate a transition system model and model-check correctness properties, and (8) revise system based on feedback from analysis tools.

## 4. DEPENDENCY ANALYSIS

Even with small systems of around 20-30 components, relationships between components and component dependences are often hard to determine from visual inspections of textual or graphical component assembly views. Bold Stroke systems can have 1000s of components, and Bold Stroke engineers have identified development of automated support for component dependency analysis and visualization as a high priority. As discussed in the previous section, Cadena provides several different layers of dependency specification and analysis with the goal of enabling incremental construction of dependency specifications – little or no specification effort should still allow useful tool feedback since a fair amount of dependency information (*inter*-component dependences) can be derived from the CAD information. Increasing the details of specifications should yield more precise visualizations and analysis. Here are the steps that we expect developers to take when creat-

ing and refining dependence information: (1) give component assembly without CPS dependence information using the global dependence default that all actions on input ports of a component  $C$  give rise to actions on all output ports of  $C$ , (2) refine by giving dependences without taking into account modal behavior, (3) refine by considering modes in CPS dependence declarations, (4) refine by giving behavioral descriptions (which capture dependence information via control-flow properties). Bold Stroke developers currently use dependency information in manually to determine non-functional aspects such as distribution, connection implementation (synchronous vs. non-synchronous calls), rate group assignment, etc. At any point in the steps above, Cadena can leverage partial dependence information to provide automated support for developers.

## 4.1 Basic notions of dependency

Given a component library and component assembly description (along with optional Cadena property specification file), Cadena’s port-level dependency module builds a *port dependence graph* PDG =  $(N, E)$  where each node  $n \in N$  is a component/port pair  $i.p$ . Edges (i.e., dependences) between PDG nodes arise from two sources: *inter-component dependences* corresponding to port connections specified in component assembly description, *intra-component dependences* captured by CPS declarations in component property specifications. Whether or not intra-component dependences are generated for a particular instance  $C$  depends on the *default dependence setting* for  $C$  as discussed previously. The default setting is given by the global default dependence declaration unless a component-local default declaration exists.

For inter-component dependences, when there is a connection between  $i_1.p_1$  and  $i_2.p_2$  in the component assembly description, we say that  $i_1.p_1$  is *event dependent* on  $i_2.p_2$  (written  $i_2.p_2 \xrightarrow{e} i_1.p_1$  – the arrow pointing in the direction of the event flow) if  $p_2$  (resp.  $p_1$ ) is an event source (resp. sink). Similarly, with the above connection,  $i_1.p_1$  is *interface dependent* on  $i_2.p_2$  (written  $i_2.p_2 \xrightarrow{m} i_1.p_1$ ) when  $p_2$  (resp.  $p_1$ ) is a facet (resp. receptacle). For example, from the CAD information in Figures 1 and 3, we have, e.g.,  $\text{GPS.outDataAvailable} \xrightarrow{e} \text{AirFrame.inDataAvailable}$  and  $\text{GPS.dataOut} \xrightarrow{m} \text{AirFrame.dataIn}$ .

For intra-component dependences, for an instance  $i$  of component type  $c$ ,  $i.p_1$  is *trigger dependent* on  $i.p_2$  (written  $i.p_2 \xrightarrow{t} i.p_1$ ) when either (1)  $p_2$  is declared to trigger  $p_1$  in the CPS for  $c$ , or (2) the default dependency status for  $c$  is *all* and there exists no trigger declaration for  $p_2$  in the Cadena specification for  $c$ .

As with conventional work on dependences, a system slice for a particular point(s) of interest (referred to as the *slicing criterion*) is computing by taking the transitive of the PDG from the PDG node(s) corresponding to the slicing criterion. Basic slicing actions provided by Cadena include forward slice, backward slice, and slice intersections.

## 4.2 Mode-aware dependences

To reason about mode-aware dependences, the mode state of the system is captured formally via a mode-state vector  $m$  which holds values for one or more mode variables from the system being analyzed. In the ModalSP scenario, it is useful to consider a two-variable mode-state vector that holds the mode state of NavSteering and the mode state of TacticalSteering. Given a PDG  $P = (N, E)$  for a system, a modal PDG  $P_m = (N_m, E_m)$  for mode-state vector  $m$  is formed by setting  $N_m = N$  and having  $E_m$  include all inter-component edges, but only intra-component edges that are enabled according to  $m$ .

Cadena provides mechanisms for collecting a set of mode-state vectors and using these to drive visualization of dependences (i.e., Cadena users can choose to visualize dependences for a particular vector). Mode-state vector sets can be entered explicitly in a

form-based view or generated automated from the state-exploration techniques discussed in the following section. For instance, for the mode-vector mentioned above, it is instructive to have a mode-based dependency view for the three mode-state vectors (disabled, disabled), (enabled, disabled), and (disabled, enabled).

## 4.3 Dependency-driven analyses

In the Bold Stroke development process, several non-functional system aspects that are currently designed using manual efforts primarily can be aided or even synthesized automatically using the dependence analysis capabilities described above. These include (following the order in which they are carried out) assigning priorities/execution-rates to event consumer ports, appropriately distributing component instances to network nodes, and identifying opportunities for switching asynchronous remote event delivery (the default mechanism) to synchronous local method calls.

Automated rate assignment begins by assigning rates to each event consumer port that subscribes to a time-triggered event – the port simply is assigned the rate of the event. Using the results of the dependency analysis above, the process continues by propagating rate information along the PDG in a forwards direction and assigning the propagated rate value to each input and output port encountered. In cases where a port has more than one rate propagated to it (e.g., when event correlation is used, or when two different input ports influence an output port), the highest of the rates is propagated. The process continues until a fixpoint is reached and the resulting rates on event consumer ports bind CAD rate variables.

In the example in Figure 1, automated rate assignment would result in assigning 1Hz to the event consumer of PilotControl, and to the receptacles of PilotControl and the facets of TacticalSteering and NavSteering connected to PilotControl. Similarly, (a) all ports in Navigator, NavSteeringPoints are assigned 5Hz, and the two ports of NavSteering connected to NavSteering are assigned 5Hz, and (b) all ports in GPS and AirFrame are assigned 20Hz. There is now a conflict for the rates on the output ports of NavSteering due to the fact both 5Hz and 20Hz rates are flowing in, so the higher rate of 20Hz is used. The process continues until the remainder of the unassigned ports have a value of 20Hz.

The distribution algorithm then uses the rate information gathered above (a) to determine the traffic on the connections between components, and (b) to identify components to be deployed on a common location. In the example, the algorithm would group components closer to their trigger source with the traffic and rate information used as the arbitrating criteria.

In the example, Navigator and PilotControl would be assigned distinct locations, 11 and 12. The rest of the components would be assigned location 13 as the traffic between them is higher assuming all data and event types are of unit size. However, if the traffic on the data connection between Navigator and NavSteeringPoints was higher than the cumulative traffic on other connections on NavSteeringPoints then NavSteeringPoints would be assigned location 11. Although this simplistic example is not a realistic example, the ability to automatically leverage connection and rate information to provide developers with guidance about component distribution can be a significant advantage for large systems.

For the reduction of asynchronous remote event deliveries, an event delivery between two component instance ports  $i_1.p_1$  and  $i_2.p_2$  that does not involve correlation can be reduced to a local method call when  $i_1$  and  $i_2$  are co-located and when the rates attached to  $p_1$  and  $p_2$  through the propagation above are the same. In the example, this optimization can be applied to all non-correlated event connections. However, if NavSteeringPoints and NavSteering were assigned different locations in the distribution step above, the optimization would not apply to that connection.

Finally, although we do not implement schedulability analysis in

Cadena, we note that Cadena’s dependency specifications (in particular, mode-aware dependence information) can be used to improve static scheduling. Currently, static schedulability analysis in Bold Stroke is based on summing execution costs along call-tree paths deduced from component connections only (i.e., our all dependence mode with no declared dependences). Cadena specifications prune away many infeasible dependences, and therefore prune away infeasible paths that may cause worst-case execution time estimates to be more conservative than necessary. This can sometimes save a surprising amount of development time since systems are often restructured in significant ways to obtain schedulable computations.

## 5. MODEL-CHECKING DESIGNS

As illustrated in the previous section, light-weight dependence analyses can provide a wealth of information about relationships among design components. In addition to this, Cadena supports deeper semantic analysis of design behavior using model checking. Specifically, we support reasoning about logical properties of component-based designs expressed as assertions, invariants and sequencing properties over system states and actions, such as method calls and returns and event publications and consumptions.

In order to maximize the flexibility of Cadena in targeting different classes of component-based systems, we have designed a layered translation from our extended CCM-based specification languages to the input language of the DSpin [7] model checker. The translation includes modeling of: (i) design component interfaces and behavior, (ii) the semantics of middleware components through which component execution is orchestrated, and (iii) event and data sources and sinks in the system environment. These translation aspects have well defined interfaces that make it easy to vary, for example, the semantics of middleware functions to suit a particular application domain. In the remainder of this section, we discuss each of these aspects in turn as well as our approach to specifying the properties to be checked. Unlike much of the existing work in model checking system designs, we found it necessary to exploit knowledge of the middleware and environment to achieve models that were compact enough to check in a reasonable amount of time. We describe how we abstracted domain knowledge for the Bold Stroke architecture to encode it into our models. We conclude with a discussion of our experiences model checking properties of several variations of models generated for the design from Figure 1.

### 5.1 Why DSpin?

Cadena uses DSpin as its model checking engine. In principle we could use any one of a number of available model checking tools, such as Spin [13] or NuSMV [2], however, component-based designs have a number of features that are difficult to express in the low-level input languages of such tools. For example, one needs to be able to define an object, i.e., a collection of data attributes, manipulate references to an object, and invoke the methods associated with an object. It is clearly possible to map such high-level constructs onto a model checker input language as JPF [12] and Bandera [4] do, but it is much easier when the model checker supports those constructs directly. DSpin is an extension to Spin that adds support for objects, functions, and references, among other features. DSpin is implemented in such a way that it runs as least as fast as Spin for the functionality they have in common [7] and our experience is that the performance penalty for using the extensions is minimal when compared to hand-optimized models.

### 5.2 Component Modeling

Translating Cadena components is straightforward. A component is implemented as a group of state variables, for attributes and modes, and DSpin function references, for the receptacle methods consumed from other components. Associated with each compo-

```
any NavSteering_internalData;
mode NavSteering_componentState;
ftype Ref_NavSteering_dataIn1_getData,
      Ref_NavSteering_dataIn2_getData;
ftype Ref_NavSteering_update;

function Fun_NavSteering_source1 (mtype t) {
  printf("NavSteering: source1 handler invoked.\n");
  if
  :: NavSteering_componentState == enabled ->
    NavSteering_internalData =
      Ref_NavSteering_dataIn1_getData ();
    printf("NavSteering: publishing update.\n");
    Ref_NavSteering_update (NavSteering_DataAvailable)
  :: else
  fi
}

function Fun_NavSteering_switch_getData () : int {
  atomic {
    P <= 1 ->
      printf("NavSteering: switch getData invoked.\n");
      P = MaxPriority
  }
  return NavSteering_componentState;
}
```

Figure 6: DSpin model for NavSteering BModal Component (excerpts)

```
proctype RateGroup_1Hz () {
  ftype f;
  mtype m;
  ...
  do
    :: skip ->
      S_timeout?b;
    ...
    do
      :: Rate1_queue?[f, m] -> Rate1_queue?f(m); f(m)
      :: else -> break
    od
  od
}
```

Figure 7: DSpin model of Event Channel Rate-specific Thread

nent are a group of functions that implement the event consumer methods (i.e., handlers) and methods provided by the component.

There are two advantages to this translation: it has a natural mapping back to the Cadena model which facilitates expressing diagnostic information about detected errors and it decouples the component from other components so that models can be easily re-configured. For example, the NavSteering component, shown in Figure 6, does not encode the identity of source1 from which it reads dataIn1. Rather, the component has a function reference that is assigned to the appropriate method reference based on configuration information. We have generated models with static configurations to date, but it is trivial to support dynamic reconfiguration.

### 5.3 Modeling Middleware Services

CCM systems assume the presence of middleware services such as an event-channel with a pool for dispatching threads to execute component code.

*Modeling Event Services:* In our DSpin models an event publication is achieved by sending the function reference for the component’s event handler and the identity of the event as a message to the process modeling the event-channel thread. That thread then invokes the event handler code for the component instance as illustrated in Figure 7, where ftype is a DSpin function reference and mtype is an enumeration encoding the events in the system.

It is easy to identify pairs of component instances where one publishes an event that is consumed by the second. Under certain constraints the behavior of those components may be sequenced, for

```

function Proxy_NavSteering_update (mtype t) {
  int i = 0;
  printf("NavSteering-Proxy: Calling subscriber methods.\n");
  do
    :: i < NavSteering_update_NumberSubscribers ->
      NavSteering_update_SubscriberList[i].Entry(t);
      i = i + 1
    :: else -> break
  od
}

```

Figure 8: DSpin Model of intra-Rate-Group Push Proxy

example when they have the same rate assignments in a Bold Stroke application. Under these conditions, the generic function-event pair queuing mechanism described above may be replaced by direct calls from the component instance publishing the event to the handlers for component instances subscribed to that event. For example, all publications of *dataAvailable* events from the *NavSteering* component are made by calling the *Ref\_NavSteering\_update* function reference which is bound to the function in Figure 8. Sequencing execution of event publications and consumer code yields a smaller state space<sup>4</sup> by reducing the data states associated with the thread queues, e.g., *Rate1\_queue*.

Each event correlation in the system has its own DSpin function. This function is generated based on the automaton that defines the meaning of the correlation expression [21]. The correlation function acts as a handler for its input events, updates the state of the automaton, and when an accepting state is reached it publishes the correlated event to subscribers using the same mechanisms as described above. Since the correlation functionality is internal to the middleware service its internal steps are unobservable to the application, thus we model them as atomic transitions.

*Modeling Thread Services:* Middleware provides the threads on which application components execute, and it may also define a scheduling policy for those threads. When such a policy is available it can be exploited to reduce the state space of the generated model by eliminating interleavings of thread executions that violate the scheduling policy. Eliminating such interleavings also has the beneficial effect of improving the precision of analysis performed on the model.

Bold Stroke applications use rate monotonic scheduling [15] for event-channel threads. Rate monotonic scheduling is a pre-emptive priority based scheduling policy where higher rates are assigned higher priorities. Like most model checkers, DSpin does not support the definition of a specific scheduling policy, so we encode the policy directly in the DSpin model. This is achieved by guarding all component actions with a test that blocks the action if the component’s priority is less than the current runnable priority, which is stored in a global variable *P*. The print statement of function *Fun\_NavSteering\_switch\_getData* in Figure 6 illustrates such a guard. Guarded component actions are only enabled when the current runnable priority has been decremented to the component’s priority. A decrement is performed only when there are no enabled steps in the model which can be detected by the *timeout* predicate of Spin. Since this priority decrementing process must operate independent of component or event-channel thread execution it is modeled as the separate process shown in Figure 9.

The resulting model has several interesting properties. It assures that the highest-priority runnable action will be performed; this yields a dramatic reduction in the system state space as discussed below. Note that components running at the highest system wide priority need not have their actions guarded. This, combined with the direct call modeling of event publication and handling, means that high-priority behavior effectively executes as a single atomic

<sup>4</sup>A similar event-channel performance optimization is applied quite frequently in Bold Stroke applications.

```

active proctype PriorityHandler () {
  do
    :: timeout ->
      d_step {
        if
          :: P > 0 -> P = P - 1;
          :: else
            fi
        }
      od
}

```

Figure 9: Rate Selection Process

step in the model. The introduction of an explicit global priority does add a state variable to the system, but note that it only changes value when no other transitions in the model are enabled. Consequently, there are no possible interleavings of the different priority values with component/thread execution and the effect on the state space is trivial.

## 5.4 Environment Modeling

Cadena models capture the combined behavior of a collection of component instances working in concert to respond to external inputs and to produce appropriate outputs. We use the term *environment* to describe the entities that interact with the explicitly modeled system. Since Cadena models do not attempt to accurately model data values flowing between the environment and the system the only relevant inputs are environment initiated events. The semantics of those events and the pattern of event arrival at the system will vary with each application.

Our experience suggests that accurate modeling of environment initiated events is necessary both for precision in reasoning and for state space reduction. The Cadena tools have builtin support for generating environment models for Bold Stroke system designs. These systems are driven by periodic events generated by the middleware. The rates of these events are typically harmonic to enable reasoning about schedulability via rate monotonic analysis.

Our generated transition system models do not represent time explicitly, rather they constrain the number of timeout event publishes for a given rate relative to timeout publishes for its adjacent rates. For example, in the interval defined by a pair of 5 Hz timeout events there must be four 20 Hz timeouts. Constraining the timeout events appropriately is achieved by including a separate *Timer* process in the transition system that keeps track of an abstraction of time and triggers timeout events appropriately.

For a system with harmonic rates, one could simply keep a counter,  $\tau$ , that is incremented from 0 up to the maximum rate,  $m$ , by one to maintain an abstract time. For a  $k$  Hz rate group, initiation of the timeout event would then be guarded by testing that:

$$\tau \% m/k == 0$$

$m/k$  is guaranteed to be a whole number since the rates are harmonic. If the rates are not harmonic, then instead of the maximum rate, the counter is incremented up to the least common multiple (LCM) of the rate groups in the system and the rate specific guards use LCM rather than  $m$  in their modulo tests.

Depending on the exact rates used in a system we can reduce the granularity of abstract time and achieve a state space reduction by reducing the number of values that  $\tau$  will take on. To do this we scale the LCM and each of the rates down by their greatest common factor (GCF) and adjust the modulo tests appropriately. For example, if the rates in a system are 5, 10 and 15, then the LCM is 30, the GCF is 5, and we increment  $\tau$  from 1 up to 6. The generated timer process for such a system is shown in Figure 10.

Rather than use the event publication mechanisms described in the previous section, for timeout events we use rendezvous channels to couple the timer and the processes that model rate-specific event channel threads (see Figure 7). The rate-specific processes



```

proctype Timer () {
  int t = 0;
  do
    :: (t >= 6) -> t = 0
    :: (t < 6) ->
      if
        :: (t % 2) == 0 -> S_timeout15!1
        :: else
          fi;
      if
        :: (t % 3) == 0 -> S_timeout10!1
        :: else
          fi;
      if
        :: (t % 6) == 0 -> S_timeout5!1
        :: else
          fi;
        t = t + 1
      od;
  }
}

```

Figure 10: Timeout Generation Process for 5, 10 and 15 Hz Rate Groups

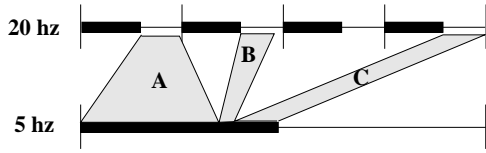

Figure 11: Interleaving of Rate Group Thread Execution

force all processing of published events handled by components in that rate group to complete before executing the rendezvous with the timer. Figure 11 illustrates the possible behaviors that can arise in the generated transition system as a result of `Timer`'s behavior and the enforcement of rate monotonic scheduling. Processing in each rate group is forced to complete before the next timeout for that rate group. Processing in lower-priority rate groups can occur only after higher-priority processing has completed. No attempt is made in the transition system, however, to ensure that the amount of lower-priority processing that occurs is appropriate, either by restricting the amount that can occur (e.g., region A in Figure 11 performs an infeasibly large amount of work) or by forcing it to occur (e.g., the region between regions B and C in Figure 11 performs an infeasibly small amount of work).

## 5.5 Property Specification

We divide the problem of stating correctness properties of Cadena designs into two parts: defining observations of the behavior of the system that one wishes to make and defining patterns of observations that constitute correct system behavior. Our approach is similar to the one taken in the Bandera Specification Language [5].

In Cadena designs user's may wish to reason about the call or return from a component method, the publication or consumption of an event, or the values of component modes. These basic observations can be qualified by component instance identity (e.g., a method call to a specific instance), parameter values (e.g., the return of a specific value from a method), component ports (e.g., the handling of an event on a specific component port), or rate groups (e.g., publishing an event from a specific rate group). The syntax for defining these *observables* mirrors the syntax of CCM and the Cadena extensions defined in this paper.

User's can instantiate an existing set of property specification patterns [9] with Cadena observables to form specifications of desired system behavior. In addition, Cadena generates observable definitions in a format that is compatible with the Timeedit tool [22]. Timeedit supports graphical specification of properties that are made up of complex chains of observations. Figure 12 illustrates a Timeedit specification for the constrained response property: "when a 20 Hz timeout occurs and navigation steering mode

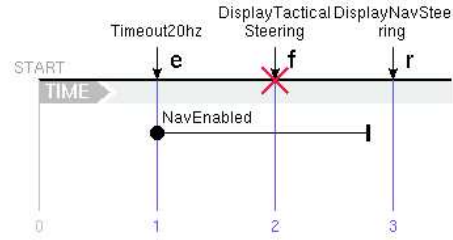

Figure 12: Timeline property

is enabled, the display will be updated by the navigation component and not the tactical component".

## 5.6 Experience

We have model checked properties of several Cadena designs. The most interesting of these is the modal scenario of Figure 1.

As a point of comparison, we generated a DSpin model for this scenario that did not enforce the rate-monotonic scheduling policy and performed an exhaustive state-space exploration for the number of timeouts issued in a single second of system execution. We ran DSpin using the maximal state compression settings available (which are the same Spin's compression settings) and the check aborted after generating 26 million states using 1 Gigabyte of RAM. Clearly, some form of state space reduction was necessary. A state-space exploration on a model of the same design that encoded rate-monotonic scheduling for an arbitrary number of timeouts, ran in less than a minute and generated 1.4 million states using 130 Megabytes of RAM. Similar state space sizes were found for all of our checks on the modal scenario.

We attempted to check several assertions, invariants and the display mode related response property shown in the previous section. The property from Figure 12 failed on the model with non-deterministic scheduling due to the fact that execution of a 20 Hz component was preempted by a 1 Hz component. Thus, the steering component mode settings could change after the 20 Hz timeout and before the display update occurred. This is clearly infeasible in the actual system and performing the check on the rate-monotonic model described above bore that out by verifying the property.

The modal scenario is unrealistic in the number of components, but it is quite realistic in the number of rate groups. Recall that high-priority component execution is effectively atomic in models that encode rate-monotonic scheduling. This suggests that the rate of growth of the state space with increasing numbers of high-priority components will be linear whereas increasing numbers of lower-priority will yield faster rates of growth. We are conducting experiments with a variety of Cadena designs of Bold Stroke applications and plan to report on the scalability of our approach.

## 6. RELATED WORK

There has been a large body of work on on timing and schedulability analysis for component-based systems. As these techniques have matured, they have been integrated into environments that support the development of real-time systems. For example, MetaH [23] and Geodesic [6] are frameworks that support the reuse of components written in Ada and Java, respectively, in real-time systems. These frameworks include a range of timing analyses and automatically generate infrastructure code that coordinates the execution of component code in a way that achieves the system's timing requirements. Cadena is complementary to this work in that it targets logical properties of a system using both light-weight and heavy-weight analysis techniques.

Ptolemy [17] is a framework that allows a wide variety of formal descriptions of components and their behavior to be integrated into a single system. User's provide sufficient detail in these de-

scriptions to allow implementations to be automatically generated. Ptolemy provides a run-time infra-structure to mediate between components that have different execution models. In contrast, Cadena models intentionally leave out detail in order to provide more abstract system descriptions that are amenable to analysis for large systems. While Cadena provides some code generation capabilities, we do attempt to generate component method implementations.

Dependence analysis has a long history of uses in program understanding, transformation, maintenance and testing (e.g., [14]). Our use of dependence analyses is essentially an adaptation of existing techniques to the level of abstraction present in CCM designs. Unlike most program dependence analyses which work from a fixed language definition, we have engineered the annotation languages in Cadena to provide a layering of detail that will allow for more precise dependences to be calculated and exploited for improved user feedback.

Model checking [3] has become extremely popular as a technology for analyzing behavioral models of software artifacts. Researchers have extracted such models from source code (e.g., [12, 4]), UML design artifacts (e.g., [18, 16]) and architectural descriptions (e.g., [1]). The difficulty with all applications of model checking is scaling it up to apply to realistically large and complex systems. Recent years have seen an enormous amount of research on the systematic abstraction of models to enable more tractable reasoning. We take a different approach in Cadena by exploiting the *natural* abstractions that arise when developing high-level design models of systems.

Our model extraction techniques are based on our experiences with Bandera [4]. We have adapted those techniques to exploit knowledge of the execution environment of Bold Stroke applications. This can provide significant state space reduction, but, in support of broad applicability of Cadena to CCM-based systems it was important to engineer the model extraction framework to accommodate the semantics of different middleware infrastructures in the spirit of Garlan [10].

## 7. CONCLUSION

Component frameworks have proven to be effective in dealing with the challenges associated with building complex distributed systems. We believe that the high-level architectural descriptions used by CCM and other component oriented frameworks are an excellent vehicle for injecting light-weight formal methods and sophisticated automated analysis techniques across the entire software development process. In particular, we have built Cadena to explore how static analysis and model-checking can be integrated into CCM development by capitalizing on the use of CCM IDL to define what are, in effect, system abstractions that make such checking feasible for realistic systems.

We have applied Cadena to small and simple avionics systems based on the Boeing Bold Stroke architecture, and the initial results are encouraging. We believe that the strategies that we have developed for modeling middleware event services can scale reasonably well to larger systems. However, for systems with 1000s of components as one would find in product-line applications, we plan to investigate the use of compositional checking. In addition, there are many other forms of analysis needed for developing product-line avionics applications; Cadena current focuses on dependence analysis and behavioral analysis using model-checking techniques.

Concerning the tool itself, we believe building Cadena as a plugin to IBM's Eclipse using the OpenCCM tools can provide a tool environment robust enough to experiment with designs of real systems. We are plan to do an alpha-release of Cadena to our research partners in late October, with a full public release coming early next year. More information about the tool (with example artifacts and screen shots) can be found at [www.cis.ksu.edu/](http://www.cis.ksu.edu/)

santos/cadena.

## 8. REFERENCES

- [1] R. Allen and D. Garlan. A formal basis for architectural connection. *ACM Transactions on Software Engineering and Methodology*, July 1997.
- [2] A. Cimatti, E. Clarke, F. Giunchiglia, and M. Roveri. NuSMV : a new symbolic model checker. *International Journal on Software Tools for Technology Transfer*, 2(4):410–425, 2000.
- [3] E. Clarke, O. Grumberg, and D. Peled. *Model Checking*. MIT Press, 2000.
- [4] J. C. Corbett, M. B. Dwyer, J. Hatcliff, S. Laubach, C. S. Păsăreanu, Robby, and H. Zheng. Bandera : Extracting finite-state models from Java source code. In *Proceedings of the 22nd International Conference on Software Engineering*, June 2000.
- [5] J. C. Corbett, M. B. Dwyer, J. Hatcliff, and Robby. A language framework for expressing checkable properties of dynamic software. In *Proceedings of the SPIN Software Model Checking Workshop*, volume 1885 of *Lecture Notes in Computer Science*, Aug. 2000.
- [6] D. de Niz and R. Rajkumar. Geodesic - a reusable component framework for embedded real-time systems. Technical report, Carnegie Mellon University, 2002.
- [7] C. Demartini, R. Iosif, and R. Sisto. dspin : A dynamic extension of SPIN. In *Theoretical and Applied Aspects of SPIN Model Checking (LNCS 1680)*, Sept. 1999.
- [8] B. Doerr and D. Sharp. Freeing product line architectures from execution dependencies. In *Proceedings of the Software Technology Conference*, May 1999.
- [9] M. Dwyer, G. Avrunin, and J. Corbett. Patterns in property specifications for finite-state verification. In *Proceedings of the 21st International Conference on Software Engineering*, May 1999.
- [10] D. Garlan and S. Khersonsky. Model checking implicit-invocation systems. In *Proceedings of the 10th International Workshop on Software Specification and Design*, Nov. 2000.
- [11] GOAL. The OpenCCM platform. <http://corbaweb.lifl.fr/OpenCCM/>, 2002.
- [12] K. Havelund and T. Pressburger. Model checking Java programs using Java PathFinder. *International Journal on Software Tools for Technology Transfer*, 1999.
- [13] G. J. Holzmann. The model checker SPIN. *IEEE Transactions on Software Engineering*, 23(5):279–294, May 1997.
- [14] S. Horwitz and T. Reps. The use of program dependence graphs in software engineering. In *Proceedings of the 14th international conference on Software engineering*, pages 392–411. ACM Press, 1992.
- [15] M. H. Klein, T. Ralya, B. Pollak, and R. Obenza. *A Practitioner's Handbook for Real-Time Analysis: Guide to Rate Monotonic Analysis for Real-Time Systems*. Kluwer Academic Publishers, 1993.
- [16] D. Latella, I. Majzik, and M. Massink. Automatic verification of a behavioural subset of UML statechart diagrams using the SPIN model-checker. *Formal Aspects of Computing*, 11(6):637–664, 1999.
- [17] E. A. Lee. Overview of the ptolemy project. Technical Report UCB/ERL M01/11, University of California, Berkeley, Mar. 2001.
- [18] J. Lilius and I. P. Paltor. vUML: A tool for verifying UML models. In *Proceedings of the 14th IEEE International Conference on Automated Software Engineering*, 1999.
- [19] D. Sharp. Reducing avionics software cost through component based product line development. In *Proceedings of the Software Technology Conference*, Apr. 1998.
- [20] D. Sharp. Object oriented avionics software flow policies. In *Proceedings of the 18th AIAA/IEEE Digital Avionics Systems Conference*, Oct. 1999.
- [21] H. Sipma. Event correlation: A formal approach. Technical Report Draft, Stanford University, July 2002.
- [22] M. H. Smith, G. J. Holzmann, and K. Etessami. Events and constraints: a graphical editor for capturing logic properties of programs. In *Proceedings of the 5th International Symposium on Requirements Engineering*, Aug. 2001.
- [23] S. Vestal. Metah user's manual. <http://www.htc.honeywell.com/metah>, 1998.